



elo-cart

Versatile, durable, elegant.

NEW PRODUCT



iTD QUALITY >>

THE NEW ROLLSTAND elo-cart: VERSATILE, DURABLE, ELEGANT.

Dear Customer,

With the elo-cart roll stand, iTD is expanding its portfolio of medical equipment carts. The elo-cart is an equipment cart with a column design for simple applications with one piece of equipment and a centered load. Its areas of application include:

- Endoscopy
- Ventilation
- Monitor Roll Stand
- Patient monitoring
- ECG
- Ultrasound

The product sets a new standard for **usability, quality** and **design**, all at a competitive price.

The elo-cart roll stand offers the following benefits:

- The modular product system allows individual user requirements to be realized quickly and cost-effectively
- Increased satisfaction of medical staff thanks to high quality materials, easy adjustment, and effortless mobility
- Differentiation based on quality and sophisticated design
- Low transport costs thanks to flat packing and low weight
- Approval as a Class 1 medical device in accordance with MDR 2017/745 (requirements as per IEC 60601-1) reduces the regulatory workload and minimises the usage risks
- Quick assembly

This catalogue features examples of applications, accessories and technical details. Our experts would be happy to assist you with configuring your own equipment cart at any time.

The iTD team

BASIC PRODUCT CONFIGURATIONS FOR VARIOUS APPLICATIONS



MONITOR ROLL STAND



ECG



VENTILATION





ULTRASOUND



PATIENT MONITORING



SINGLE-USE ENDOSCOPY

MODULAR PRODUCT DESIGN: FAST REALIZATION OF DIVERSE REQUIREMENTS



The elo-cart incorporates a flexible modular design, which enables the timely and cost-effective implementation of unique configurations. The cart can be easily adapted to accommodate future changes to requirements.



Various attachment options are available for installing monitors, all-in-one PCs or tablets. These come in both fixed and tiltable versions.



Shelves, trays and bins of various sizes can be selected for equipment, accessories and consumables. These can be easily extended with add-on modules such as cable hooks and universal holders. The trays, bins and shelves can be adapted to specific requirements.



There is an array of application-specific and universal accessories available that allow you to finalize (z not s) your configuration.

FOCUS ON ERGONOMICS

In addition to incorporating all the necessary components, creating a user-friendly configuration prioritizes ergonomic workplace design.

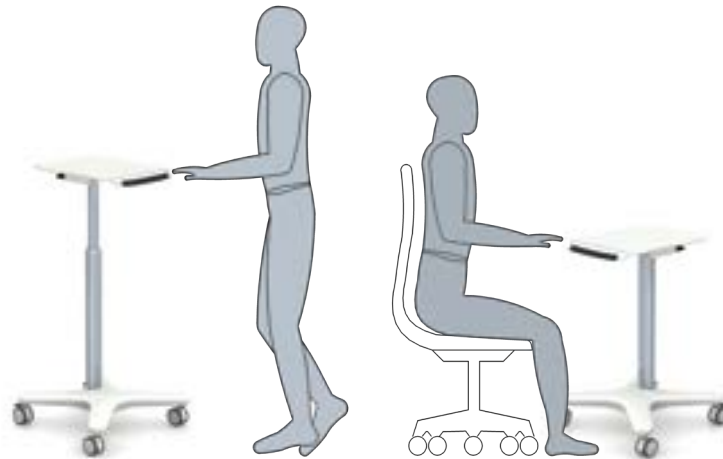

We offer a range of column lengths and an optional height-adjustable column, to accommodate different user heights, both standing and seated use positions.



Accessories can be positioned at the same level as the shelf and the multifunctional tray or bin, ensuring optimal ergonomics.



With the optional swivel arm, the monitor will always be in the user's line of sight, allowing them to remain focused on the patient.

THE MULTIFUNCTIONAL TRAY AND BIN: VERSATILE, USER-FRIENDLY, ROBUST

When paired with the tray and bin frame, the modular functionality presents a wide array of configuration options.



The trays and bins can simply be taken out of the frame for cleaning.



The add-on modules are clicked into their designated slots in the tray and bin frame or shelf without any tools and can be moved at any time, if necessary.



Add-on modules are clicked into the tray or bin frame. Unoccupied slots are covered by the edge of the tray or bin to avoid contamination.

APPLICATION EXAMPLES



Single-use endoscopy

Item number: MR.6008.993

Rollstand, 36 U (total height: 1,221 mm), equipped with:

- 1 basic frame with 4 lockable castors, Ø 75 mm
- 1 multifunctional tray, shallow, with handle
- 1 multifunctional bin, deep
- 1 cable winder
- 1 monitor holder with VESA 75/100, universal tiltable
- 1 endoscope holder (parking position)
- 1 mount for single-use endoscope (packed)
- 2 cable clips
- 1 counterweight set (4 kg)

Installation height:	36 U (1,056 mm)
Load capacity:	40 kg
Finish, base:	RAL 9016 Traffic white powder-coated
Finish, support column:	Anodised
Condition on delivery:	Semi-assembled

Ventilation

Item number: MR.6003.993

Rollstand, 26 U (total height: 997 mm), equipped with:

- 1 basic frame with 4 lockable castors, Ø 75 mm
- 1 centre shelf, large, with click-in modules
- 1 multifunctional bin, deep
- 1 cable winder
- 1 shelf for respiratory humidifier
- 1 tube arm
- 1 gas bottle holder
- 2 cable clips

Installation height:	26 U (832 mm)
Load capacity:	40 kg
Finish, base:	RAL 9016 Traffic white powder-coated
Finish, support column:	Anodised
Condition on delivery:	Semi-assembled



Monitor elo-cart

Item number: MR.6004.993

Rollstand, 45 U (total height: 1,605 mm), equipped with:

- 1 basic frame with 4 lockable castors, Ø 75 mm
- 1 monitor holder with VESA 75/100, tiltable
- 1 rear push handle
- 2 cable clips
- 1 counterweight set (4 kg)
- 1 counterweight set (5 kg)

Installation height:	45 U (1,440 mm)
Load capacity:	40 kg
Finish, base:	RAL 9016 Traffic white powder-coated
Finish, support column:	Anodised
Condition on delivery:	Semi-assembled



Patient monitoring

Item number: MR.6000.993

Rollstand, 33 U (total height: 1,221 mm), equipped with:

- 1 basic frame with 4 lockable castors, Ø 75 mm
- 1 monitor holder with universal adaptor, tiltable
- 1 multifunctional bin, deep, with handle
- 1 3-part cable hook
- 1 cable winder
- 2 cable clips

Installation height:	33 U (1,056 mm)
Load capacity:	40 kg
Finish, base:	RAL 9016 Traffic white powder-coated
Finish, support column:	Anodised
Condition on delivery:	Semi-assembled

APPLICATION EXAMPLES



ECG

Item number: MR.6001.993

Rollstand, 36 U (total height: 1,317 mm), equipped with:

- 1 basic frame with 4 lockable castors, Ø 75 mm
- 1 monitor holder with VESA 75/100, tiltable
- 1 multifunctional tray, shallow, with handle
- 1 multifunctional bin, deep
- 1 3-part cable hook
- 2 cable winders
- 2 cable clips

Ultrasound

Item number: MR.6005.993

Rollstand, total height 800 mm–1,100 mm (top edge to floor), equipped with:

- 1 basic frame with 4 lockable castors, Ø 75 mm
- 1 multifunctional bin, deep
- 1 universal holder
- 1 cable winder
- 2 cable clips
- 1 holder for ultrasound probes
- 1 shelf for printer
- 1 mains adaptor holder

Installation height:	36 U (1,152 mm)
Load capacity:	40 kg
Finish, base:	RAL 9016 Traffic white powder-coated
Finish, support column:	Anodised
Condition on delivery:	Semi-assembled

Installation height:	589 mm
Load capacity:	40 kg
Finish, base:	RAL 9016 Traffic white powder-coated
Finish, support column:	Anodised
Condition on delivery:	Semi-assembled

COMPONENTS FOR INDIVIDUAL REQUIREMENTS

Please feel free to discuss your specific component requirements with us.

While this catalog showcases numerous examples of how the equipment cart can be customized for different applications, the diverse range of accessories allows for countless more.

If you have a configuration not outlined in this catalog, we would be happy to assess your needs and explore the possibility of developing customized components in direct collaboration with you.



iTD ONLINE TOOLS

CONFIGURE PRODUCTS STEP BY STEP

The online product configurator offers many advantages:

- Intuitive user interface
- Step-by-step product configuration
- 3D product presentation
- Automatic stability check
- Configurations managed in the user account
- Price calculation for registered users





BASIC FRAME

Basic frame

The elo-cart basic frame has a small footprint compared to other iTD products, but maintains excellent stability. The elo-cart is designed for centered loads and is therefore well-suited to applications with single-component devices. The aluminum die-cast base is adaptable to various caster sizes and counterweights. The aluminum die-cast base can accommodate various castor sizes and counterweights. The support column, constructed from a closed, extruded aluminum profile with a trapezoid cross-section, facilitates effortless accessory installation. It eliminates the need for drill holes, threads, or notches in the column. This design not only offers aesthetic benefits but also simplifies the process of hygienic cleaning.

Load capacity: 40 kg
Material: Aluminium/plastic (castors and cap)
Finish: RAL 9016 Traffic white powder-coated/clear anodised
Scope of delivery: 1 basic frame, semi-assembled with 4 lockable castors

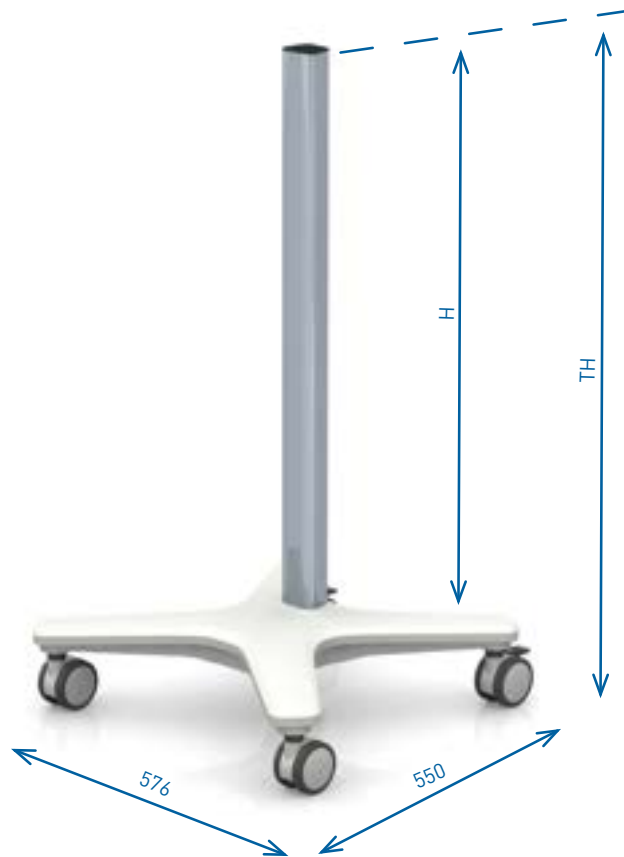

Installation height H	Total height TH	Castors Ø	Item number
26 U (832 mm)	997 mm	75 mm	MR.5000.993
33 U (1,056 mm)	1,221 mm	75 mm	MR.5001.993
36 U (1,152 mm)	1,317 mm	75 mm	MR.5002.993
42 U (1,344 mm)	1,509 mm	75 mm	MR.5003.993
45 U (1,440 mm)	1,605 mm	75 mm	MR.5004.993

BASIC FRAME

Basic frame with height adjustment and monitor holder with VESA 75/100

The elo-cart's height adjustment functionality guarantees that the integrated equipment can be easily adjusted to an ergonomically suitable height. This is particularly beneficial for transitioning between standing and sitting positions or accommodating individuals of varying heights. The integrated gas spring provides up to 300 mm of easy height adjustment. Additionally, the lower section of the support column can be used for attaching additional accessories, regardless of the height setting selected. In this version, the height adjustment release button is located on the rear of the inside column. The included VESA 75/100 monitor holder allows an installed monitor to be tilted +15°/-7°.

Load capacity: basic frame: 40 kg
monitor holder: max. 5 kg*

Material: Aluminium/plastic (castors and cap)

Finish: RAL 9016 Traffic white powder-coated/clear anodised

Scope of delivery: 1 basic frame, semi-assembled with 4 lockable castors

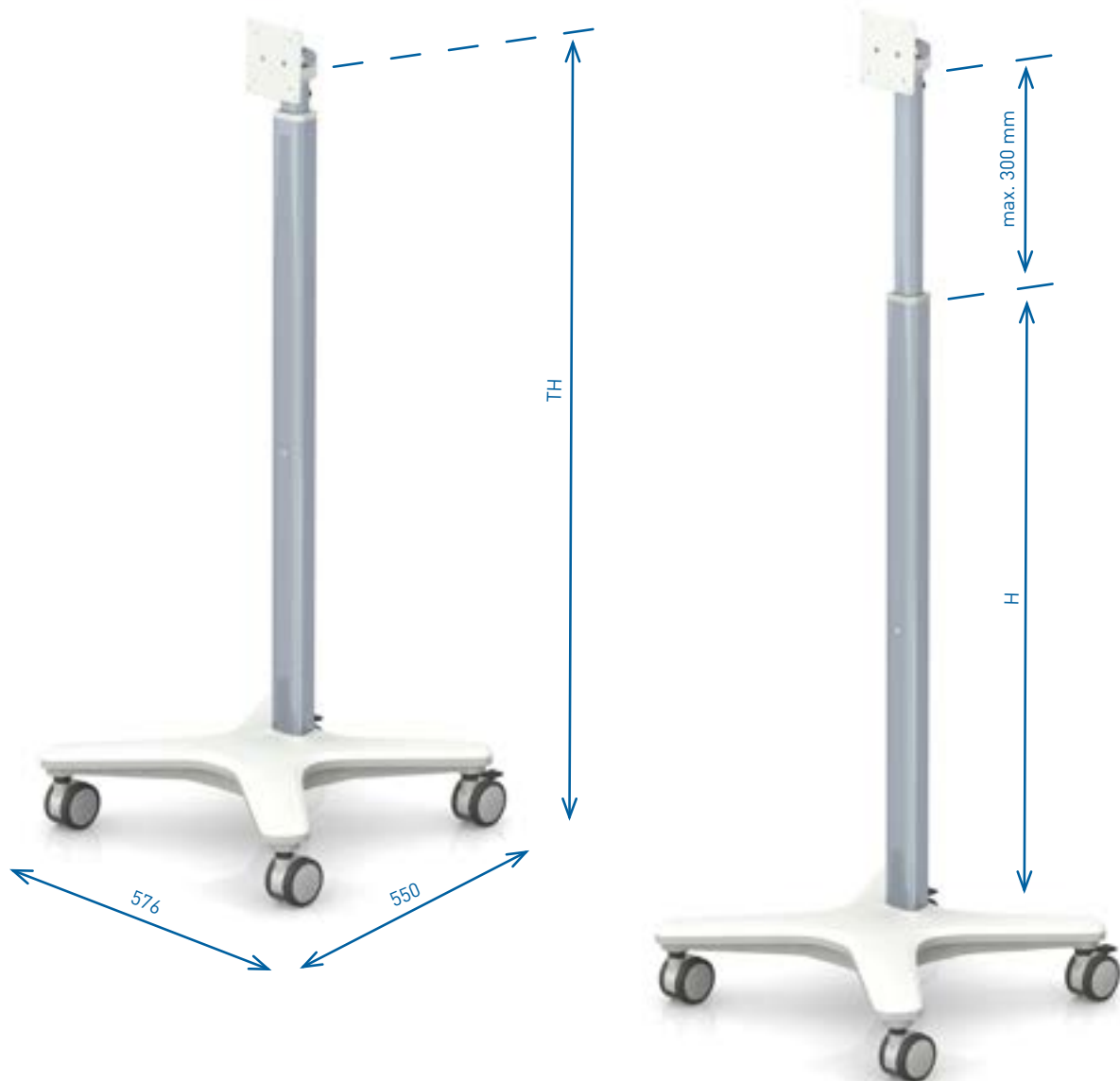

Installation height H	Total height TH	Castors Ø	Item number
949 mm	1,200 mm–1,500 mm	75 mm	MR.5005.993

* Larger monitor weights must be checked on the basis of the monitor depth.

BASIC FRAME

Basic frame with height adjustment and tablet holder

The height adjustment of the elo-cart means the integrated equipment can always be positioned at an ergonomically comfortable height, for example when switching between standing and sitting or for adjustment to different people's heights. The integrated gas spring almost effortlessly assists with adjusting the height setting by up to 300 mm. Regardless of the height adjustment, the lower section of the support column can be used for attaching additional accessories.

The height adjustment release button is located on the rear of the inside column. The included tablet holder allows a tablet to be tilted $+90^{\circ}/-30^{\circ}$, swivelled $\pm 30^{\circ}$ and rotated 360° .

Load capacity: basic frame: 40 kg
 tablet holder: max. 2 kg
 Material: Aluminium/plastic (castors and cap)
 Finish: RAL 9016 Traffic white powder-coated/clear anodised
 Delivery contents: 1 basic frame, semi-assembled with 4 lockable castors

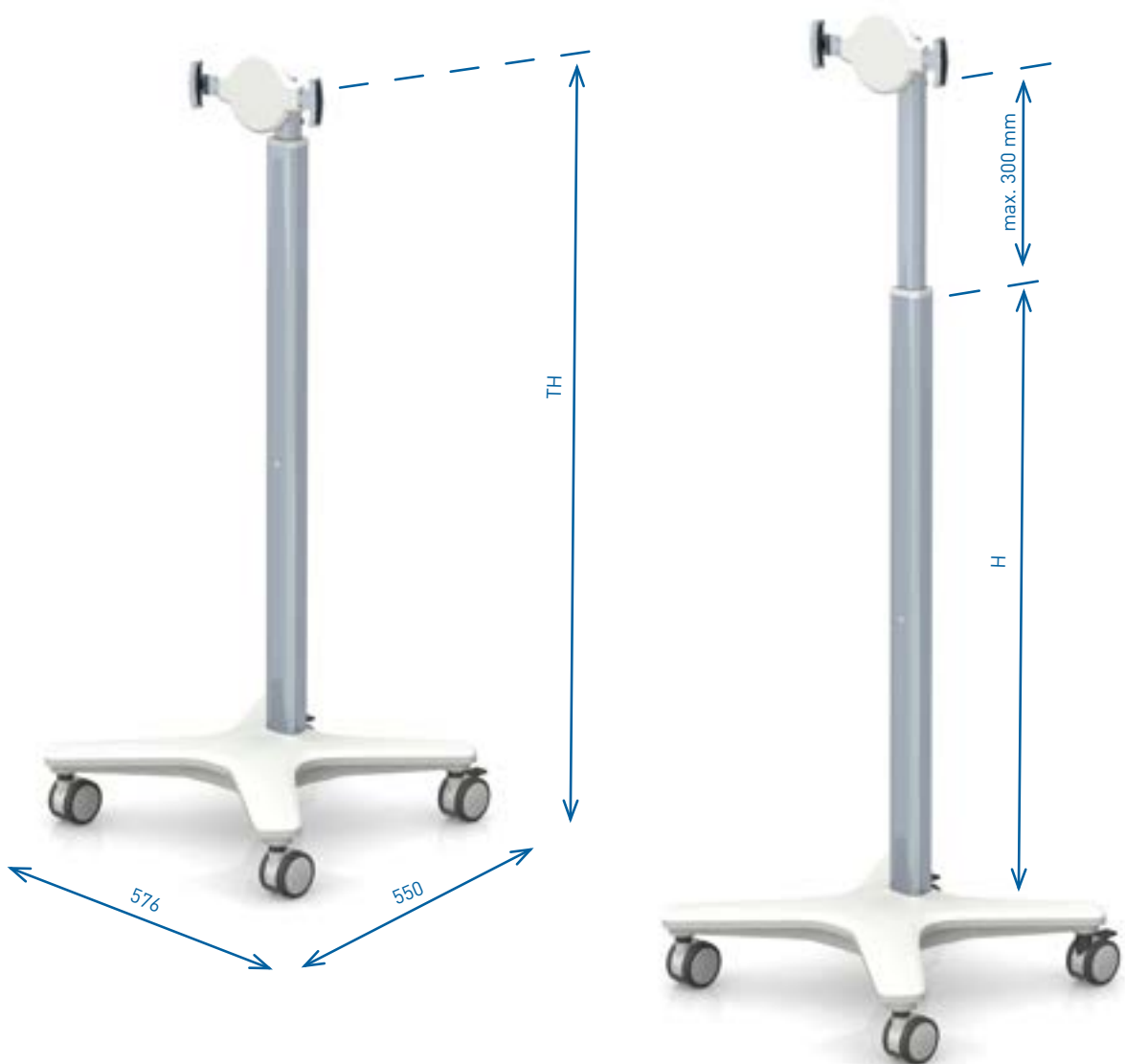

Installation height H	Total height TH	Castors \emptyset	Item number
949 mm	1,200 mm–1,500 mm	75 mm	MR.5006.993

BASIC FRAME

Basic frame with height adjustment and small centre shelf

The height adjustment release lever is located on the right, under the shelf. Equipment carts with a shelf allow add-on modules to be used. These extensions make it possible to always position accessories and consumables at an ergonomically sensible height alongside or behind the equipment. The integrated gas spring almost effortlessly assists with adjusting the height setting by up to 300 mm. In this version, the shelf's usable size is 366 mm x 342 mm (W x D).

Load capacity: basic frame: 40 kg
shelf: max. 10 kg
Material: Aluminium/plastic (castors and cap)
Finish: RAL 9016 Traffic white powder-coated/clear anodised
Delivery contents: 1 basic frame, semi-assembled with 4 lockable castors

elo-cart

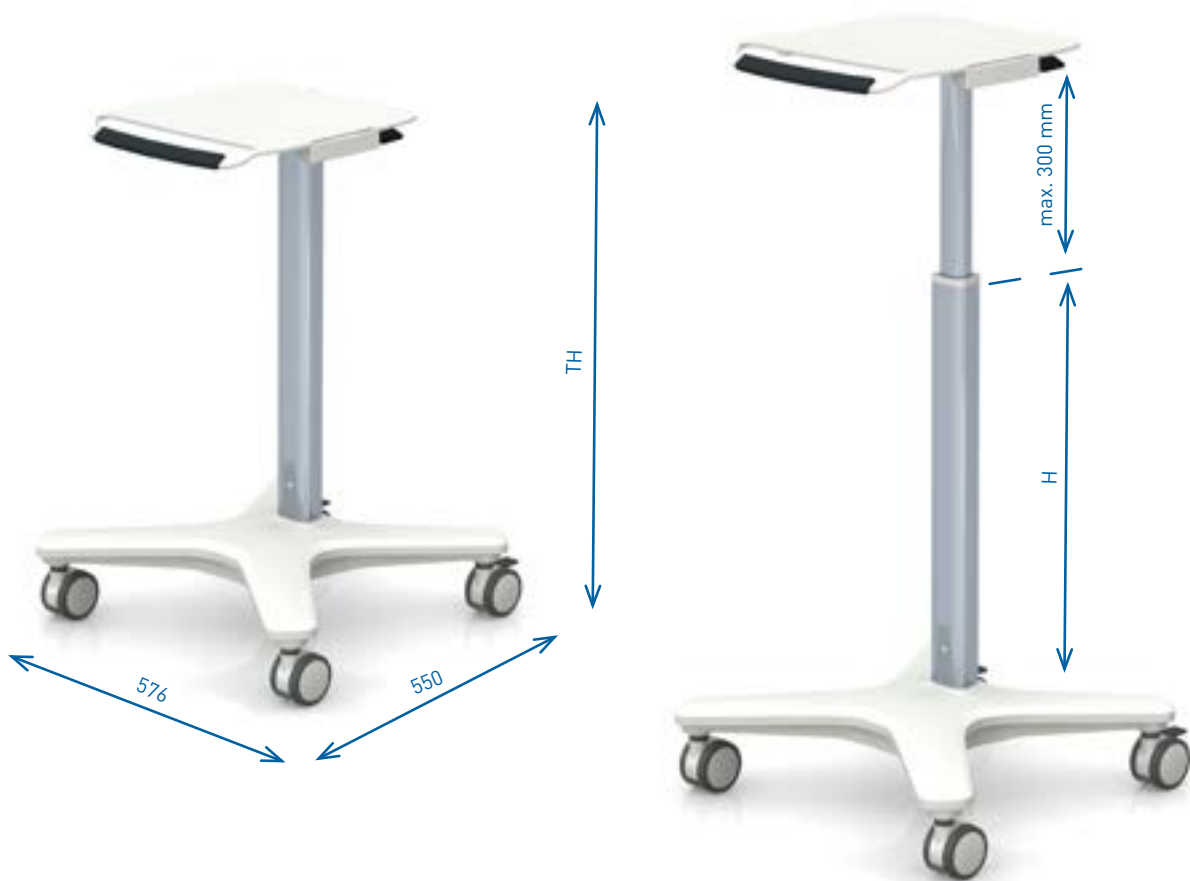

Installation height H	Total height TH	Castors Ø	Item number
589 mm	800 mm–1,100 mm	75 mm	MR.5007.993

BASIC FRAME

Basic frame with height adjustment and large centre shelf

In this version, the height adjustment release lever is located on the right, under the shelf. Equipment carts with a shelf allow add-on modules to be used. These extensions make it possible to always position accessories and consumables at an ergonomically sensible height alongside or behind the equipment. In this version, the shelf's usable size is 366 mm × 442 mm (W × D).

Load capacity: basic frame: 40 kg
 shelf: max. 10 kg
 Material: Aluminium/plastic (castors and cap)
 Finish: RAL 9016 Traffic white powder-coated/clear anodised
 Delivery contents: 1 basic frame, semi-assembled with 4 lockable castors



Installation height H	Total height TH	Castors Ø	Item number
589 mm	800 mm–1,100 mm	75 mm	MR.5009.993

BASIC FRAME

Castor conversion kit

Castors are available in a larger diameter of 100 mm instead of 75 mm, for safe manoeuvring over larger thresholds and for improved cart handling.

Material: Plastic, colour similar to RAL 9016 Traffic white/RAL 7005 Mouse grey
Scope of delivery: 4 castors, 2 of which lockable, diam. 100 mm



elo-cart

Designation	Item number
Castor conversion kit, diam. 100 mm	ZV.9156.999

Counterweight set

Depending on the total height, the components selected and the load capacity, counterweights will need to be used to achieve sufficient stability.

Material: Steel
Finish: Galvanised
Installation: Under the base, ① centrally; ② in the stabilisers
Scope of delivery: ① 1 counterweight or ② 4 counterweights including installation materials

Designation	Item number
① Counterweight, 1 × 4 kg	MR.3011.999
② Counterweight set, 4 × 1.25 kg	MR.3012.999

Rear push handle

The generous width of the rear handle enables users to grasp it comfortably from different positions, ensuring effortless pushing whether the cart is in front of or beside them. The handle is equipped with a soft-grip insert made of TPE* and has a rounded shape, providing a pleasant tactile experience and a secure grip.

Material: 2-component plastic
Colour: RAL 9016 Traffic white/RAL 7016 Anthracite grey
Installation: Directly on the support column, freely positionable
Scope of delivery: 1 push handle including installation materials



Designation	Item number
Rear push handle	MR.3010.993

Cable clip

The cable clip is designed for convenient fastening of the power cable to the support column. It features a snap lock that can securely hold up to three cables. The cable clip can be easily attached to any location on the support column without the need to remove any other components.

Material: Plastic
Installation: Directly on the support column, freely positionable
Scope of delivery: 1 cable clip



Designation	Item number
Cable clip	MR.0032.161

SHELVES

Center shelves, small and large

The elo-cart's shelves are specifically designed to accommodate equipment positioned at the top of the support column. All shelf variations are equipped with a comfortable push handle made of TPE*. Standard options include two different sizes, both of which can be expanded with add-on modules. These extensions allow for the placement of accessories and consumables at ergonomically appropriate heights, either alongside or behind the equipment. If necessary, the shelves can also be customized to meet your specific requirements.

Dimensions: ① and ② usable: 366 mm × 342 mm (W × D)
 ③ and ④ usable: 366 mm × 442 mm (W × D)
 Load capacity: 10 kg
 Material: Aluminium/plastic (handle and click-in modules)
 Finish: RAL 9016 Traffic white powder-coated
 Installation: At top of support column
 Scope of delivery: 1 shelf, 3 click-in modules including installation materials

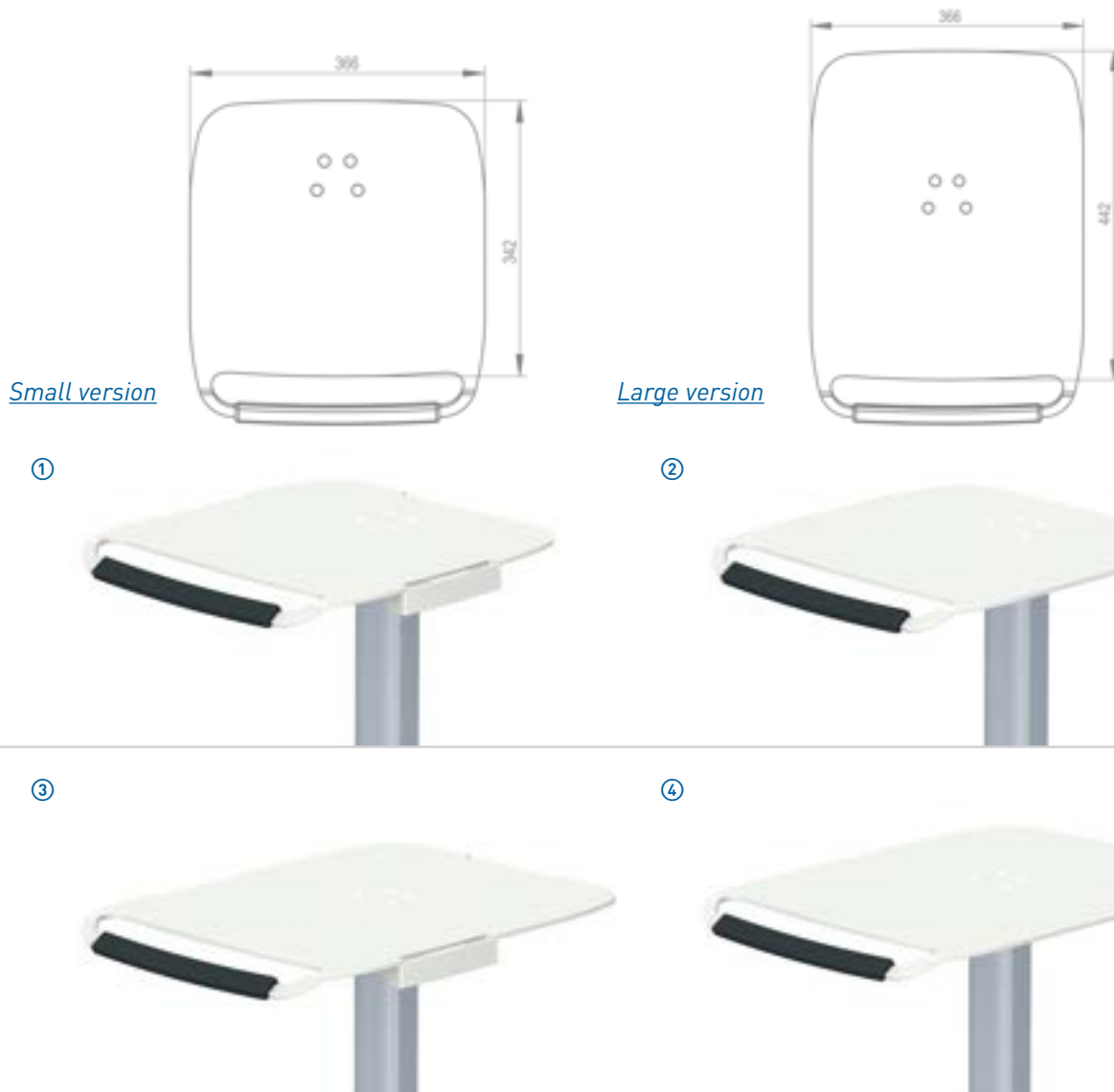

Designation	Item number
① Shelf, small, with click-in modules	MR.3013.993
② Shelf, small, without click-in modules	MR.3014.993
③ Shelf, large, with click-in modules	MR.3015.993
④ Shelf, large, without click-in modules	MR.3016.993

MULTIFUNCTIONAL TRAYS AND BINS

Multifunctional shallow trays and deep bins

The central element of the elo-cart is the versatile multifunctional trays/bins. With adjustable height options, they are available in various depths and can be chosen with or without a handle. It serves as the foundation for expansion using add-on modules. These modules are offered as standard solutions in the catalog, or they can be customized to meet specific customer requirements. In the case of the handleless version, the modules can be placed on all four sides of the frame. The version with a handle allows for add-on modules to be attached on either side or at the back. By positioning the add-on modules on the basket, it ensures accessories are at an ergonomically suitable height. Furthermore, this optional frame handle is equipped with a comfortable TPE* insert, enhancing usability and grip.

Dimensions: ① and ② interior: 299 mm × 209 mm (148 mm) × 45 mm (W × D × H)
 ③ and ④ interior: 294 mm × 204 mm (143 mm) × 150 mm (W × D × H)

Load capacity: 3 kg

Material: Plastic

Colour: Tray/bin frame: RAL 9016 Traffic white/RAL 7016 Anthracite grey; tray/bin: frosted, translucent

Installation: Directly on the support column, freely positionable

Scope of delivery: 1 tray or bin frame, including installation materials

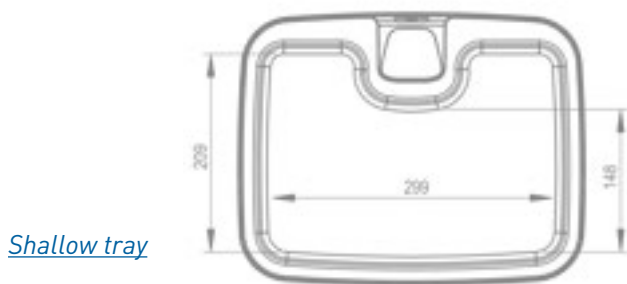

Designation	Item number
① Multifunctional tray, shallow	MR.3007.993
② Multifunctional tray, shallow, with handle	MR.3005.993
③ Multifunctional bin, deep	MR.3008.993
④ Multifunctional bin, deep, with handle	MR.3006.993

ADD-ON MODULES FOR CUSTOMIZED CONFIGURATIONS

Add-on modules enable multifunction trays/bins and shelves to accommodate diverse applications. These accessories can be easily attached in various positions without tools. The mounting position can be adjusted as desired. Those featured in the catalog represent the basic portfolio. Custom options can also be developed to meet your specific requirements.



ADD-ON MODULES FOR SHELVES AND MULTIFUNCTIONAL TRAYS AND BINS

Cable winder

1 cable winder for hanging up the power cable/2 cable winders to wind the power cable around.

Load capacity: 1 kg
Material: Plastic
Colour: RAL 9016 Traffic white
Installation: On shelf with click-in modules or on multifunctional tray or bin
Scope of delivery: 1 cable winder



Designation	Item number
Cable winder	MR.0034.161

3-part cable hook

The 3-part cable hook can hold multiple cable loops and makes orderly patient cable storage easier, especially in the areas of ECG and patient monitoring.

Load capacity: 1 kg
Material: Plastic
Colour: RAL 9016 Traffic white
Installation: On shelf with click-in modules or on multifunctional tray or bin
Scope of delivery: 1 3-part cable hook



Designation	Item number
3-part cable hook	MR.0035.161

Universal holder

The universal holder can be used to hold cleaning wipes in a standard 5" dispenser, for waste containers with a diameter of up to 139 mm or for ultrasound gel in various bottle sizes. The standard 250 ml bottles can be placed in the holder at an angle with the opening at the bottom, allowing residual gel to be extracted quickly and easily.

Load capacity: 1 kg
Material: Plastic
Colour: RAL 9016 Traffic white
Installation: On shelf with click-in modules or on multifunctional tray or bin
Scope of delivery: 1 universal holder



Designation	Item number
Universal holder	MR.0036.161

ADD-ON MODULES FOR SHELVES AND MULTIFUNCTIONAL TRAYS AND BINS

Hooks for packed treatment equipment

This holder allows sterile-packed items, e.g. single-use endoscopes, to be hung on the back of the elo-cart. Thanks to its four hooks, various endoscope versions can be stored separately and remain conveniently within reach at all times.

Load capacity: 2 kg
Material: Steel
Finish: RAL 9016 Traffic white powder-coated
Installation: On the back of the multifunctional tray or bin with click-in modules
Scope of delivery: 1 holder



Designation	Item number
Hooks for packed, single-use endoscopes	MR.3040.993

Holder for ultrasound probes

This holder can accommodate up to two ultrasound probes. The plastic inserts are removable and easy to clean.

Load capacity: 1 kg
Material: Steel/plastic
Finish: Steel: RAL 9016 Traffic white powder-coated; plastic: RAL 7016 Anthracite grey
Installation: On shelf with click-in modules or on multifunctional tray or bin
Scope of delivery: 1 holder, 2 plastic inserts



Designation	Item number
Holder for ultrasound probes	MR.3034.993

Endoscope holder in parking position

For the purpose of storing the disposable endoscope during treatment, a specialized holder is provided. This holder securely grips the endoscope handpiece without coming into contact with the flexible end of the device.

Load capacity: 0.5 kg
Material: Steel
Finish: RAL 9016 Traffic white powder-coated
Installation: On shelf with click-in modules or on multifunctional tray or bin
Scope of delivery: 1 holder



Designation	Item number
Endoscope holder in parking position	MR.0159.183

ADAPTER PLATES / POWER PACK HOLDER

Adapter plates for monitor holders

Adapter plates are required to attach the monitors with a universal adapter. The manufacturer-specific adapter plates are bolted to the respective monitor. Added security is provided by means of locking pins on the monitor bracket.

Material: Aluminium
 Finish: Anodised
 Scope of delivery: 1 adaptor plate including installation materials

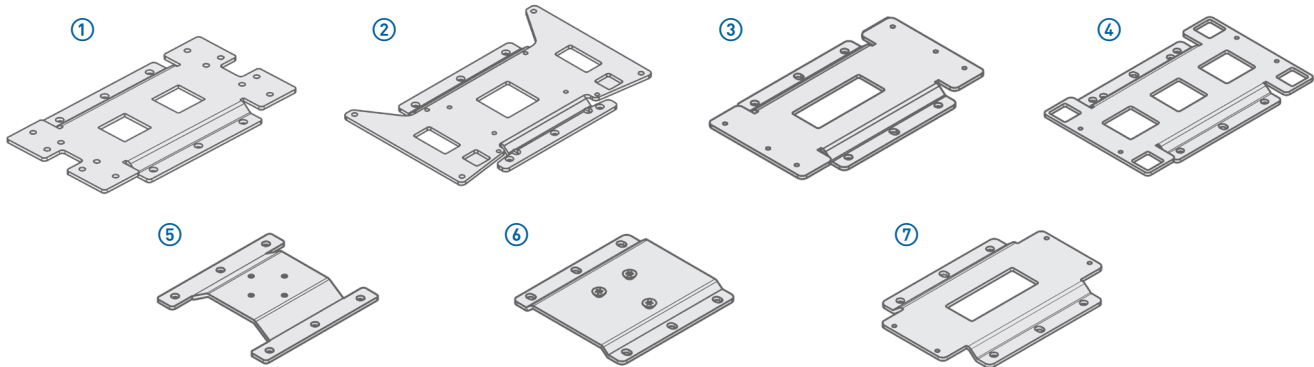

Adaptor plates for universal adaptors

Monitor manufacturer	Monitor type	Dimensions (W × D)	Item number
① Mindray	BeneView T5/T8/PM-9000	215 mm × 122 mm	TS.0657.999
② Nihon Kohden	Life Scope L/TR/PVM	214 mm × 122 mm	TS.0576.999
③ Nihon Kohden	Life Scope VS/BSM	205 mm × 122 mm	TS.0670.999
④ Nihon Kohden	SVM 7501/7503/7521/7523	200 mm × 122 mm	TS.0892.999
⑤ Philips	Efficia CM 100/120/150, SureSigns VM1-VM8	126 mm × 122 mm	TS.0469.999
⑥ Philips	Slide In for IntelliVue MX 400-800	127 mm × 122 mm	TS.0822.999
⑦ Nihon Kohden	Vismo PVM-4000	180 mm × 122 mm	TS.0904.999

• Other adaptor plates available upon request

Power pack holder for support column

The power pack holder is designed to hold power packs with a circumference of up to 250 mm and to attach them to the column of the elo-cart.

Load capacity: 3 kg
 Material: Steel/aluminium/plastic
 Finish: Steel/aluminium: RAL 9016 Traffic white powder-coated;
 plastic: black
 Installation: Directly on the support column (on the front support column),
 freely positionable
 Scope of delivery: 1 power pack holder





Bezeichnung	Item number
Power pack holder for support column	MR.3041.993

MONITOR HOLDERS

There are various holders available when it comes to attaching monitors or displays to the elo-cart. Customers can choose between a version with a tilt function or the more affordable, fixed version.

Material: Aluminium/plastic
 Finish: RAL 9016 Traffic white powder-coated; universal adaptor: anodised
 Scope of delivery: 1 monitor holder including installation materials
 Please note: Table-top mount adaptor is supplied without table-top mount

elo-cart

Function	Universal adaptor	Table-top mount adaptor (Philips)	Monitor holder with VESA 75/100 universal
Fixed	Item number: MR.3019.999	Item number: MR.3020.993	Item number: MR.3022.993
	Monitor weight: 0–10 kg	Monitor weight: 0–10 kg	Monitor weight: 0–10 kg
			

Function	Universal adaptor	Table-top mount adaptor (Philips)	Monitor holder with VESA 75/100 universal
Tiltable	Item number: MR.3042.993	Item number: MR.3043.993	Item number: MR.3045.993
	Monitor weight: 0–10 kg*	Monitor weight: 0–10 kg*	Monitor weight: 0–10 kg*
	Tilt range: $\pm 15^\circ$ 	Tilt range: $\pm 15^\circ$ 	Tilt range: $\pm 15^\circ$ 

Monitor holder with VESA 75/100 universal and mains adaptor holder			Function
Item number: MR.3023.993			Fixed
Monitor weight: 0–10 kg			
			

Monitor holder with VESA 75/100 universal and mains adaptor holder	Monitor holder with VESA 75/100	Tablet holder	Function
Item number: MR.3044.993	Item number: MR.3038.993	Item number: MR.3018.993	Tiltable
Monitor weight: 0–10 kg*	Monitor weight: 0–10 kg*	Monitor weight: 0–2 kg	
Tilt range: $\pm 15^\circ$ 	Tilt range: $+15^\circ/-7^\circ$ 	Tilt range: $+90^\circ/-30^\circ$ Swivel range: $\pm 30^\circ$ Rotation: 360° 	

STANDARD RAILS/GAS BOTTLE HOLDER

Standard rails

A standard rail can be attached to the front or back of the column to accommodate additional accessories.

Dimensions:	10 mm × 25 mm × 390 mm (D × H × L)
Load capacity:	5 kg
Material:	Aluminium/stainless steel
Finish:	Aluminium: RAL 9016 Traffic white powder-coated; stainless steel: bright
Installation:	Directly on the support column, freely positionable
Scope of delivery:	1 standard rail with adaptor including installation materials



Designation	Length	Item number:
① Standard rail, front	390 mm	MR.3028.993
② Standard rail, back	390 mm	MR.3029.993

Gas bottle holder

The gas bottle holder allows small gas bottles of up to 145 mm in diameter and 10 kg in weight to be attached to the back of the elo-cart.

Load capacity:	10 kg
Material:	Steel/aluminium
Finish:	RAL 9016 Traffic white powder-coated
Installation:	Directly on the support column, lowest possible position recommended
Scope of delivery:	1 gas bottle holder with adaptor including installation materials



Back of elo-cart

Designation	Item number
Gas bottle holder	MR.3030.993

SWIVEL ARM/TUBE ARM

Swivel arm with VESA 75/100

A swivel arm can be attached at the top of the elo-cart to achieve ergonomic positioning of lightweight monitors. The arm joints offer a swivel range of $\pm 164^\circ$, while the monitor holder itself can be rotated through 360° and be tilted by $+110^\circ$ to -20° .

Length:	360 mm
Load capacity:	2 kg*
Material:	Aluminium/plastic
Finish:	Aluminium: RAL 9016 Traffic white; plastic: black
Installation:	At the top, directly on column
Scope of delivery:	1 swivel arm including installation materials



Designation	Item number
Swivel arm with VESA 75/100	MR.3033.993

Tube arm

The tube arm enables tubes or cables to be guided from the elo-cart to the patient.

Load capacity:	Not available yet
Length:	Not available yet
Material:	Not available yet
Installation:	Not available yet
Scope of delivery:	Not available yet



Designation	Item number
Tube arm	MR.3032.993

SHELF FOR SMALL EQUIPMENT

Shelf for small equipment

The shelf surface offers space for add-ons such as small printers used in ultrasound applications or respiratory humidifiers in the case of ventilation configurations. The column adapter allows the shelf to be positioned at any height on the front of the column.

Dimensions: 224 mm × 140 mm (W × D)
Load capacity: 5 kg
Material: Aluminium/steel
Finish: RAL 9016 Traffic white
Installation: Anywhere on the front of the support column
Scope of delivery: Shelf Finish including column adaptor and installation materials

elo-cart



Designation	Item number
Shelf for small equipment	MR.3036.993

GET IN TOUCH »

» iTD GmbH • Sportplatzstraße 3 • 84381 Johanniskirchen • Germany
» Phone: +49 89 61 44 25-0
» www.itd-cart.com • sales@itd-cart.com

